



TITAN

HUNTING BLINDS

TITANBLINDS.COM

2023 PRODUCT CATALOG

BEHIND THE BLIND



ESSENTIAL BLIND REQUIREMENTS

At **Titan Hunting Blinds**, we are all hunters and we knew what we wanted in a blind. We took our research even further by meeting with well-known professional hunters, big game ranch managers and, of course, the avid bow and gun hunter.

Every hunter we spoke to provided us with ideas for what they wanted in their blind. We then took that information and broke it down into three specific requirements that we designed our blinds around. What we developed was a blind that exceeds the needs of hunters at any level.



CUSTOMER REVIEWS

“ Picked up the pro series with stand. Extremely happy with the purchase. The solid structure is great at preventing water and small insects from entering the blind, as well as odor from escaping. Would definitely recommend this unit for someone who is looking for a product that will last, and is maintenance free. Product development was well thought out. Will be ordering again. ”

“ Picked up a couple of Pro blinds and can say they are one of the best blinds I have ever hunted out of. Super quiet, great construction and attention to detail. ”

“ These are hands down the best quality hunting blinds I've ever seen. Very comfortable and durable. They look amazing and the staff are extremely welcoming. ”

“ Great deer blind! Cant wait to sit in this thing and relax in any weather condition. ”

“ Rock solid blind and the guys at Titan are awesome.. highly recommended. ”

DEFEND

Hunters need a blind that will help defend them from the natural elements making their hunt more successful. Whether it is wind, rain, snow, sleet, insects, or temperatures, Titan Blinds are made to withstand nature.



CONTAIN

Becoming part of the environment you are hunting gives you an edge on your target species. Titan Blinds are designed to help contain scent and sound as well as help conceal you from the animal you are hunting.



PROVIDE

When hunting, you never know where the animal is going to come out of the woods. Titan Blinds provide 360° of visibility and plenty of room so that you always have an opportunity to take a shot.



ROTATIONAL MOLDING

Rotational molding, also known as rotomolding, is a manufacturing process mostly used for large, one-piece hollow products.

Rotomolding is often used for items that require high-quality finishes, uniform wall thickness, and high structural integrity. Rotomolded parts are resistant to deterioration from harsh outdoor elements such as extreme temperatures, sun, rain, sleet and snow.

At Titan Hunting Blinds, we use the rotomolding process to manufacture exceptionally strong, durable, long-lasting hunting blinds and accessories.

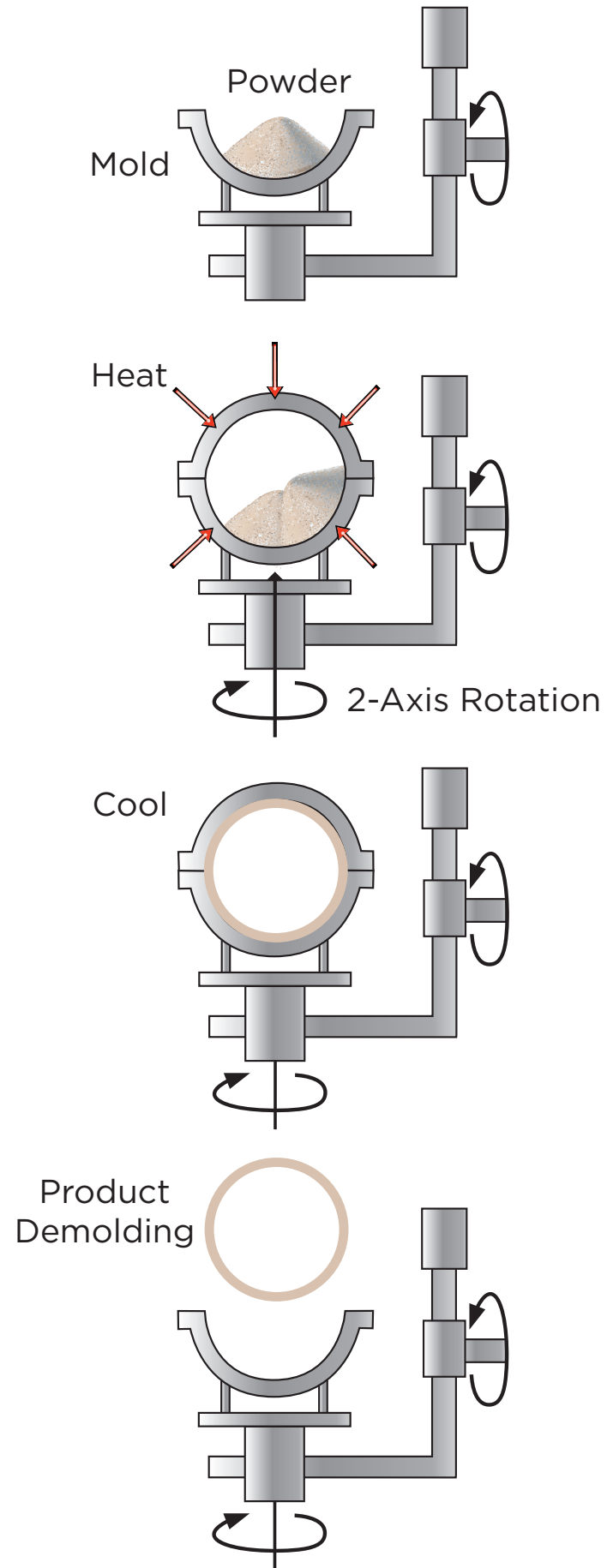

- MAKE A BLIND MOLD**
- USE POLYETHYLENE POWDER**
- FILL THE MOLD TO WEIGHT**
- ADD COLOR**
- BAKE & ROTATE THE BLIND**
- COOL THE BLIND**
- ADD WINDOWS AND DOORS**





BOW & RIFLE COMBO

PRO BLIND



The Bow & Rifle Pro Blind is built for the hunter that wants the best.

This 6' x 6' blind has enough room for you and a few friends or a family of four. Offering industry-leading features such as visibility and comfort, it is the best blind on the market today.





FEATURES

- Three horizontal rifle windows
- Four vertical bow windows
- One horizontal door window
- One-piece rotational molded construction using only the best UV stabilized polyethylene on the market
- Tinted windows
- Rotomolded door with a storage compartment
- 3" overhanging roof to keep rain off the door and windows
- Noise reduction hinges on door and windows
- Wood sub floor to provide a solid base for a stabilized shot
- Sturdy door handle with key lock
- Easy grip handle for entrance and exit from blind
- Trim seal on all edges to keep out the elements
- Marine grade carpet flooring to provide a quiet hunting experience
- One Titan Gear Box to store all your gear
- Space for up to three hunters and tall enough so that you can stand
- Proudly made in the USA

SPECIFICATIONS

Weight: 450 lbs.
 6' x 6' Base 8 sides
 Inside Wall Height: 79"
 Inside Center Height: 85"

OPTIONS

Colors  Forest Green
 Desert Storm
 Basewith or without



RIFLE

PRO BLIND



The Rifle Pro Blind is built for the hunter that wants the best.

This 6' x 6' blind has enough room for you and a few friends or a family of four. Offering industry-leading features such as visibility and comfort, it is the best blind on the market today.





FEATURES

- Three horizontal rifle windows
- One horizontal door window
- One-piece rotational molded construction using only the best UV stabilized polyethylene on the market
- Tinted windows
- Rotomolded door with a storage compartment
- 3" overhanging roof to keep rain off the door and windows
- Noise reduction hinges on door and windows
- Wood sub floor to provide a solid base for a stabilized shot
- Sturdy door handle with key lock
- Easy grip handle for entrance and exit from blind
- Trim seal on all edges to keep out the elements
- Marine grade carpet flooring to provide a quiet hunting experience
- One Titan Gear Box to store all your gear
- Space for up to three hunters and tall enough so that you can stand
- Proudly made in the USA

SPECIFICATIONS

Weight: 450 lbs.
 6' x 6' Base 8 sides
 Inside Wall Height: 79"
 Inside Center Height: 85"

OPTIONS

Colors  Forest Green
 Desert Storm
 Base with or without



8-FOOT

HUNTING BLIND BASE

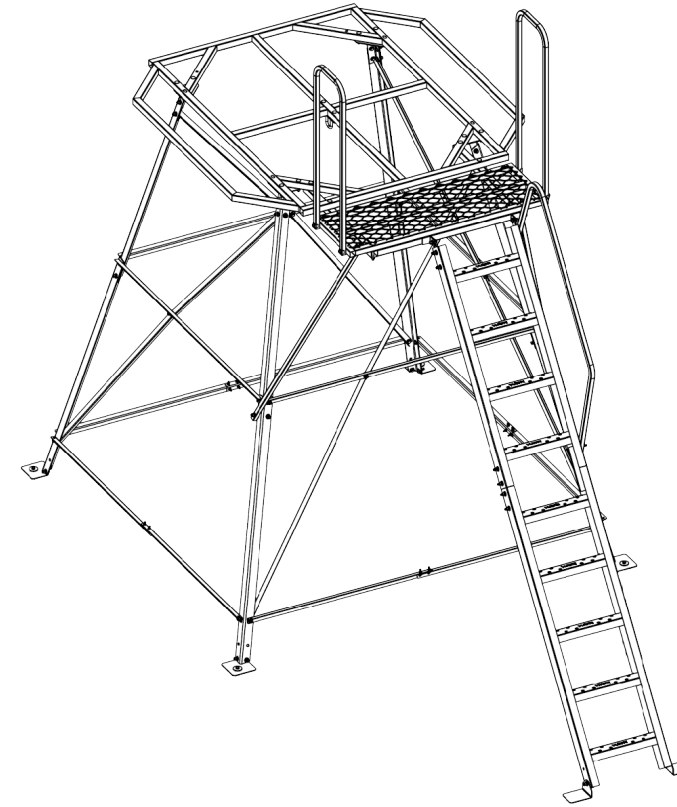

Titan Hunting Blind's 8-foot **Premier Stands** give you the ability to get your Titan Blind in the air and ready to hunt!

They are designed to work with any Titan Hunting Blind, and they are also universal in the ability to work with other blinds as well.

All Titan Premier Stands include a front porch that provides additional platform space that allows you to safely enter and exit your blind.

Our stands are also available in 4-foot.

Titan Hunting Blinds Premier Stands Feature:

- 67" X 67" Base that is designed to support the entire bottom of your Titan Blind
- Built with durable 3/16" angle steel legs
- Powder-Coated Flat Black finish provides maximum protection from the elements
- X-Bracing provides a solid tower foundation
- Front Porch with Handrails allow you to safely enter and exit your blind
- All bolt holes are precision punched (NOT DRILLED)
- Black Zinc hardware provides resistance from rusting
- Steps feature a non-slip textured punch plate design that will help ensure safe entry and exit
- Tie-Down Ring and Foot Anchor Plates allow you to safely secure your stand to the ground
- Includes four 23" long anchor leg stakes
- Auger Stake, Galvanized 3/16" Cable and Turnbuckle for securing your stand to the ground
- Assembly Instructions included
- Maximum Capacity: 600 lbs.
- Assembly Instructions included
- Proudly made in the USA
- TMA® Certified





4-FOOT

HUNTING BLIND BASE

Titan Hunting Blind's 4-foot **Premier Stands** are designed to work with any Titan Hunting Blind, and they are also universal in the ability to work with other blinds as well.

With the added height, you'll have a better vantage point to survey your herd, have more time to get ready when a deer comes in, and have more time to be ready when the deer you want to harvest shows up.

All Titan Premier Stands include a front porch that provides additional platform space that allows you to safely enter and exit your blind.

Our stands are also available in 8-foot.

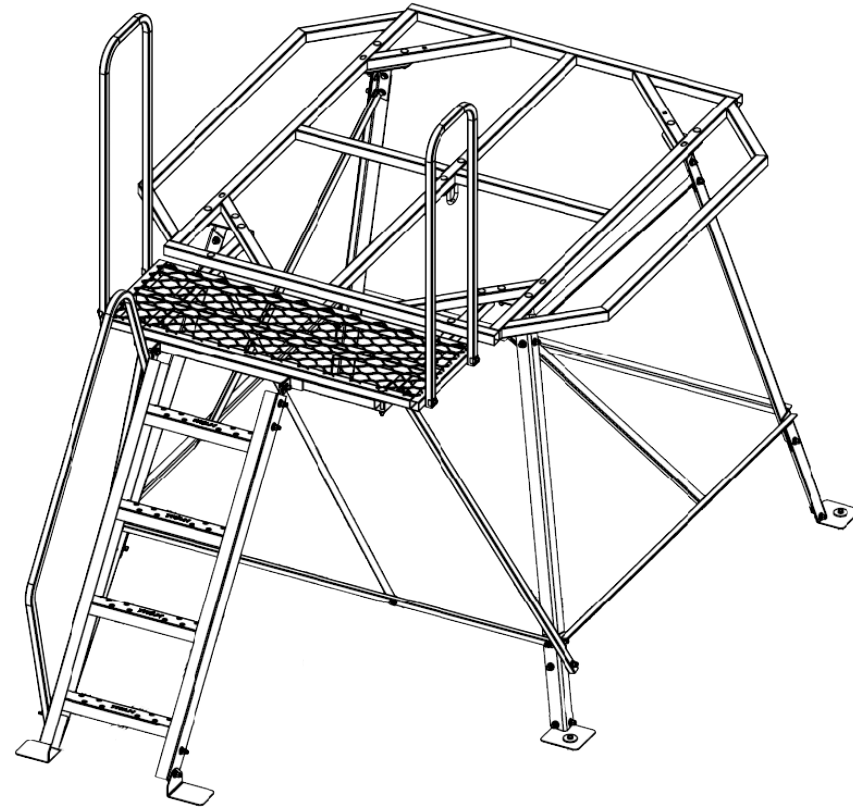

Titan Hunting Blinds Premier Stands Feature:

- 67" X 67" Base that is designed to support the entire bottom of your Titan Blind
- Built with durable 3/16" angle steel legs
- Powder-Coated Flat Black finish provides maximum protection from the elements
- X-Bracing provides a solid tower foundation
- Front Porch with Handrails allow you to safely enter and exit your blind
- All bolt holes are precision punched (NOT DRILLED)
- Black Zinc hardware provides resistance from rusting
- Steps feature a non-slip textured punch plate design that will help ensure safe entry and exit
- Tie-Down Ring and Foot Anchor Plates allow you to safely secure your stand to the ground
- Includes four 23" long anchor leg stakes
- Auger Stake, Galvanized 3/16" Cable and Turnbuckle for securing your stand to the ground
- Assembly Instructions included
- Maximum Capacity: 600 lbs.
- Assembly Instructions included
- Proudly made in the USA



TITAN SWIVEL CHAIR

HUNTING BLIND SKID



Our Titan Swivel Chair perfectly compliments any of our blinds and is the perfect choice for comfortable all-day hunting. The chair is durable and foldable, with padded armrests for added comfort.

The Titan Swivel Chair can be quickly and easily adjusted to a comfortable height, and the legs are expandable “out” for stability and “in” for packability.

The silent 360-degree operation and strap for carrying make it the perfect choice for hunters.

Specifications

- Minimum seat height — 16 inches
- Maximum seat height — 23 inches
- Weight rating — 300 lbs.



Titan Hunting Blinds Skid is designed for any Titan Hunting Blind.

The Skid is built with heavy duty steel and designed to stand up to the elements.

All Skids come in flat black with a rust-resistant coating. The Titan Hunting Blinds Skid allows you to safely move your blind and easily pull your blind to the perfect location.



Specifications

- Made from 1 1/2” steel square tubing
- Universal size to fit any Titan Hunting Blinds, DIY Blinds or competitors blinds
- Welded tie down ring
- Flat black rust-resistant coating
- Proudly made in the USA



GEAR BOX

The Titan Hunting Blinds Gear Box allows you to store all your hunting gear and accessories in one place so you don’t have to look for it when you need it.

The Gear Box can be added to any hunting blind in just minutes.

- Colors
- Forest Green
 - Desert Storm
 - Black



